

Stomacher® 4500 BAM

User Manual



Thank you for purchasing this Seward product

This manual contains operating instructions for the **Stomacher® 4500BAM**.

The **Seward Stomacher®** was originally developed in conjunction with Unilever's Research Centre at Colworth House, Bedfordshire as a solution to many of the problems previously experienced in microbiological sample preparation. Subsequently it was decided to market the instrument in response to the interest expressed in the Stomaching technique to meet the ever-increasing demands for sample preparation in a fast, consistent and efficient way. Since then, Seward have continually developed the **Stomacher®** to maintain its position as the market leader ensuring exacting performance, high quality and exceptional reliability.

The **Seward Stomacher®** is a unique homogenising instrument in which the sample is blended within a special disposable bag. The instrument acts on the bag in an action similar to the action of a stomach, hence the name **Stomacher®**.

The instrument is comprised essentially of an electric motor-driven worm gear unit with twin output shafts coupled to flexible crank mechanisms, which in turn operate two reciprocating paddles. The paddles act on the flexible plastic bag to create the blending forces termed the 'stomaching' action. An important feature of the system is that the working parts do not come into direct contact with the sample being processed. The main body of the instrument is aluminium alloy, finished with durable hygienic paint; the door and linkage assemblies are stainless steel. All the control functions and displays are ergonomically grouped and conveniently situated.

This manual provides the user with all the information to install, operate and maintain the **Seward Stomacher®**. Please read the manual carefully before using this equipment.

CAUTION: - This equipment should **not** be used if damaged in any way. If in doubt please contact your local **Seward** authorised service centre.

Should any other questions arise please do not hesitate to contact the **Seward Customer Service** Department on-

Telephone: +44 (0)1903 524 600

E-mail: info@seward.co.uk

Stomacher® is a registered Trademark and may not be used without the express permission of **Seward Ltd**.

TABLE OF CONTENTS

1. OPERATION	3
1.1 Preparing For Use.....	3
1.2 Processing.....	4
1.3 After Processing.....	4
2. STOMACHER® 4500 BAM USER INSTRUCTIONS	5
2.1 Application.....	5
2.1.1 Bag Selection and Filling.....	5
2.2 Operation	6
2.2.1 Control Key Functions.....	6
2.2.2 Display Icon Functions.....	7
2.2.3 Manual Operation.....	8
2.2.4 Automatic Operation.....	9
2.2.5 Storing Processing Programmes.....	9
2.2.6 Using Stored Processing Programmes.....	10
2.2.7 Stall Condition.....	10
3. MAINTENANCE	11
3.1 Replacing Primary Fuses.....	11
3.2 Servicing and Spare Parts.....	11
3.3. Cleaning.....	11
4. SPECIFICATIONS	12
5. WARRANTY AND SERVICING	13
6. COMPLIANCE	14
7. STORAGE AND TRANSPORT	14

1. OPERATION

1.1 Preparing For Use

Upon receipt of your **Seward Stomacher®** inspect the shipping carton for any signs of damage. Carefully unpack and inspect the instrument, reporting any obvious damage or missing parts to the supplier/dealer/carrier as appropriate.

The carton should contain the following items: -

1. One **Seward Stomacher®**.
2. One Power cord set (two on all EU models – 1 x UK plug, 1 x EU plug).
3. One User Instructions Manual.
4. One sample sachet of 50 **Seward Stomacher® Bags**.

Retain the shipping carton in case of a need to return the instrument or for long term storage. We have tried to provide the correct power cord for your market area, although if you find that the plug is not compatible with the socket outlet available it will be necessary to obtain a suitable alternative cord set.

CAUTION: - **Seward Stomachers®** are designed to operate in ambient temperatures above 10°C. Therefore, if the instrument has been stored or transported at temperatures below 10°C it should be left in an ambient greater than 10°C, for at least two hours prior to use.

CAUTION: - Before connecting the instrument to a power supply, check that the voltage and frequency details shown on the instrument are compatible with your mains electrical supply. The instrument must only be connected to a protectively earthed mains electrical supply. In the event of uncertainty, a competent qualified electrician should be consulted.

CAUTION: - Ensure that the instrument is not positioned directly against a wall or other equipment such that the ventilation slots are obstructed or restricted; we recommend that a minimum of 75mm (3") clear space around the unit is maintained.

CAUTION: - If this equipment is used in a manner not specified by Seward, protection provided by the equipment may be impaired.

1. OPERATION

Connect the **Seward Stomacher®** to the mains electrical socket using the power cord supplied. Ensure that the door is properly closed with the slotted lower hinge lugs located fully into the pivot points. Operate the power switch, which should illuminate indicating that the instrument is now ready for use.

1.2 Processing

The **Stomacher® 80 Biomaster** and **400 Circulator** are factory-set with minimal paddle clearance between the inner face of the door and the fully extended paddles. On the **Stomacher® 3500 models** and **Stomacher® 4500 BAM**, the clearance is set to 10mm. As such, it is suited to a wide range of applications.

REMOVAL OF THE REAR COVER OF THE MACHINE BY UNQUALIFIED PERSONNEL SHOULD NEVER BE ATTEMPTED. THERE ARE NO USER SERVICEABLE COMPONENTS INSIDE.

Return to the manufacturer for repair.

Removal of the rear cover will invalidate the warranty.

1.3 After Processing

Due to the infinite variety of samples that may be processed in a Stomacher® it is not possible to provide definitive procedures for every application, or give any undertaking, implied or otherwise, as to the validity of any method used. Seward Limited maintain a library of reference papers covering practical experience with the Stomacher® system over many years and these details are available to users upon request.

Do not attempt to run the instrument without the protective lining in place

2. USER INSTRUCTIONS

Seward Limited maintain a library of reference papers covering practical experience with the **Stomacher®** system over many years and these details are available to users upon request.

2. STOMACHER® 4500 BAM USER INSTRUCTIONS

2.1 Application

There are no set rules in the application of the **Stomacher®** instrument and the following is intended as a guide only and not to restrict laboratory technique.

The **Stomacher® 4500 BAM** was developed specifically for the FDA's BAM protocol for composite sampling. It can also be used for similar large volume blending applications.

2.1.1 Bag Selection and Filling

For best results it is recommended that only Genuine **Seward Stomacher® Bags** be used. Deep frozen foods should not harm the bags but hard particles such as bone, grit, fruit-stones and seeds may cause puncturing. Where a marginal condition exists or any hazardous material is being blended it is recommended that two bags are used one inside the other.

Seward provide a heavier duty (90-100 micron thickness) bag for extensive blending requirements.

If required, several bags may be processed simultaneously providing the total volume does not exceed 4500 ml. When doing so, it is recommended that they be layered vertically so that the 'load' is fairly evenly distributed over the paddle faces.

For volumes less than 1000ml an alternative **Stomacher®** model should be used.

2. USER INSTRUCTIONS

2.2 Operation

2.2.1 Control Key Functions

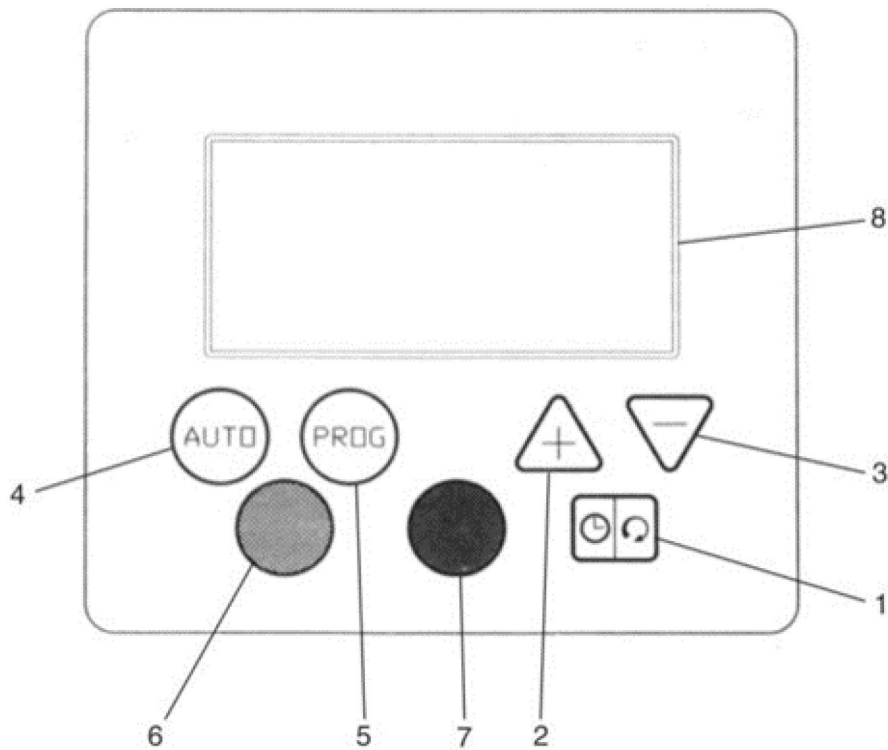

- 1. SPEED / TIME key:** - Toggles the display enunciator icon between SPEED and TIME displays.
- 2. + (PLUS) key:** Increases the value of the enunciated parameter, i.e. speed / time.
- 3. – (MINUS) key:**- Decreases the value of the enunciated parameter, i.e. speed /time.
- 4. AUTO key:**- Toggles the instrument between MANUAL and AUTO operating modes.
- 5. PROG key:** - Toggles through stored programme selection, P1, P2, P3 and no programme.
- 6. START key:** - Starts the instrument when in manual mode and initially in AUTO.
- 7. STOP key:** - Stops the instrument in either operational mode.
- 8. Liquid Crystal Display:** - Displays selected function values and status icons.

2. USER INSTRUCTIONS

2.2.2 Display Icon Functions

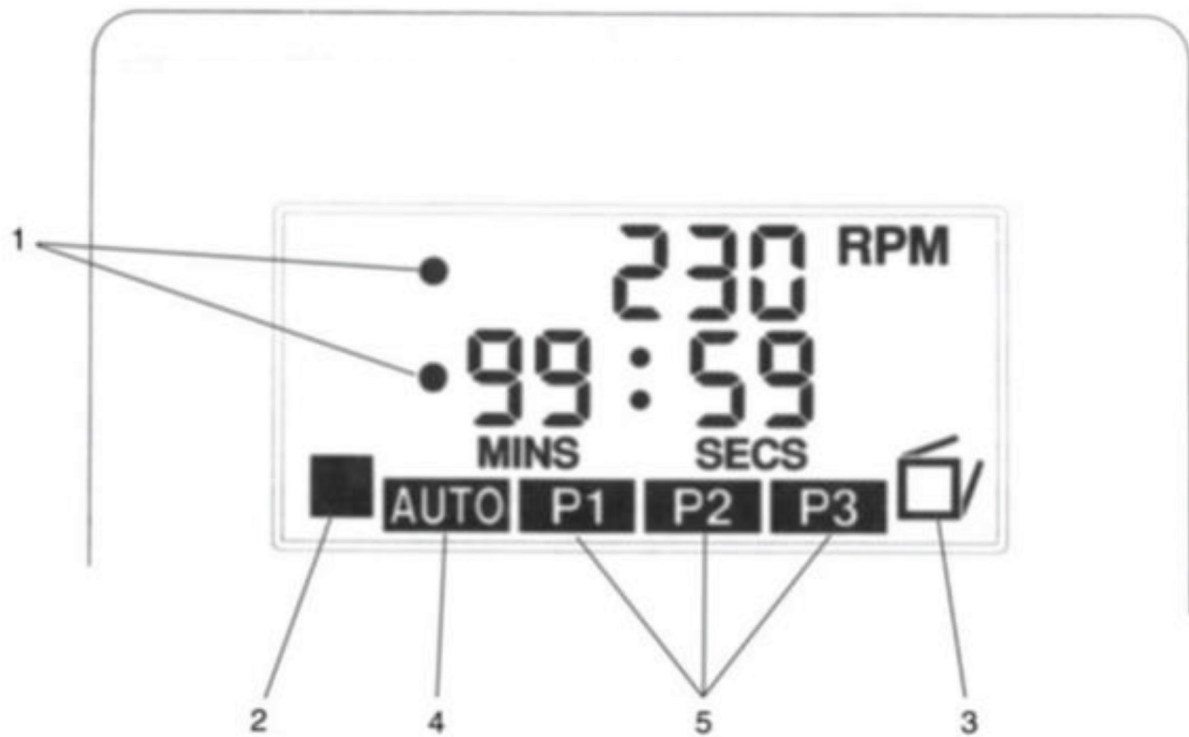

- 1. ENUNCIATOR icon:** - Continuously indicates whether the speed or time parameter has been selected.
- 2. STALL CONDITION icon:** - Displayed only when a motor stall condition has occurred.
- 3. DOOR OPEN icon:** - Displayed only when the door is open.
- 4. AUTO icon:** - Displayed only when AUTO mode is selected, there is no icon display for MANUAL mode.
- 5. P1, P2, and P3 icons:** - Displayed individually, when a stored programme is selected.

2. USER INSTRUCTIONS

2.2.3 Manual Operation

Please note that pressing any control function key is acknowledged by a short tone (0.1 seconds duration) emitted from the instruments internal sounder.

1. Ensure the POWER rocker switch is in the on (1) position. The instrument should also emit a short tone and the display should now indicate the instrument status.

2. Ensure the AUTO icon is **not** displayed. If AUTO is shown, press the AUTO key to revert to MANUAL mode. Similarly, if programmes, P1, P2, or P3 are selected, press PROG repeatedly until no programme is selected.

3. Open the door by raising the lid fully upward and back. This gives access to the paddle compartment. The DOOR OPEN icon will now be displayed.

4. Place the **Stomacher® Bag(s)** into the paddle compartment leaving 50 to 60mm protruding above the bag clamp and close the door thus clamping the bag(s). The DOOR OPEN icon will now be off.

5. The ENUNCIATOR icon indicates that the time parameter has been selected (display defaults to 30 seconds). The time parameter can now be adjusted by pressing the + or – key as required. The setting is variable between 0 seconds and 99 minutes 59 seconds in increments of 1 second. Pressing and releasing the + or – key increments the time by 1 second, holding down the + or – key accelerates the rate of change.

6. Pressing the SPEED / TIME key toggles the ENUNCIATOR icon to indicate that the speed parameter has been selected. The speed setting can now be adjusted by pressing the + or – key as required.

7. Pressing the START key will initiate the stomaching process. The instrument will run at the selected speed and duration. Please note that the time display counts down from the selected time and displays the remaining processing time. The stomaching process continues in normal circumstances until either:

- The timed cycle has finished.
- The STOP key is pressed.
- The door has been opened.
- The power has been switched off.

In all instances the time resets to the selected value.

8. After processing, simply open the door and remove the **Stomacher® Bag**. The instrument is ready for processing the next sample.

WARNING: - Opening the door during the operating cycle causes the instrument to stop. This, however, **must not** be considered the normal method for stopping the instrument

2. USER INSTRUCTIONS

2.2.4 Automatic Operation

If a number of samples are to be processed under the same conditions, i.e. speed / time values, then you may prefer to select the AUTO mode. When in AUTO the stomaching process is initiated by the opening and closing of the door between sample loadings.

1. Select speed / time values as previously described in 4.2.3.
2. Press the AUTO key, displaying the AUTO Icon.
3. Load the charged **Stomacher® Bag(s)** as previously described in 4.2.3.
4. Closing the door will initiate the stomaching process. The instrument will run at the selected speed and duration. Please note that the time display counts down from the selected time and displays the remaining processing time. The stomaching process continues in normal circumstances until either: -
 - The timed cycle has finished.
 - The STOP key is pressed.
 - The door has been opened.
 - The power has been switched off.

In all instances the time resets to the selected value.

5. When the processing is completed simply open the door, remove the processed sample and place the next sample into the instrument. Close the door and processing will commence automatically.

2.2.5 Storing Processing Programmes

It is possible to store up to three combinations of speed / time values as programmes within the instrument's memory. This enables the most frequently used or specific processing parameters to be recalled easily and efficiently.

To store or change a programme: -

1. Pressing and releasing the PROG key toggles through the three programme selections denoted by the P1, P2 and P3 icons and returns to manual (no PROG con). Please note these initially display memory-stored default values. Press and release the PROG key at the desired programme number.
2. Adjust the speed / time values as described previously in 4.2.3.
3. Simultaneously press and hold down the AUTO key and PROG Key for at least 2 seconds. This is acknowledged by a longer tone (0.5 seconds' duration). The displayed speed / time values are stored in the memory.

2. USER INSTRUCTIONS

2.2.6 Using Stored Processing Programmes

In Manual mode: -

1. Press and release the PROG key to select the desired programme. Either the P1, P2 or P3 icon should now be present on the display.
2. Load the **Stomacher® Bag(s)** as previously described.
3. Pressing the START key will initiate the stomaching process as previously described.
4. After processing, simply open the door and remove the **Stomacher® Bag(s)**. The instrument is ready for processing the next sample.

In Auto mode: -

1. Press and release the PROG key to select the desired programme. Either the P1, P2 or P3 icon should now be present on the display.
2. Press the AUTO key, displaying the AUTO icon.
3. Load the **Stomacher® Bag(s)** as previously described.
4. Closing the door will initiate the stomaching process as previously described.
5. When the processing is completed simply open the door, remove the processed sample and place the next sample into the instrument. Close the door and processing will commence automatically.

2.2.7 Stall Condition

The drive controller has a factory-set electrical current limiting device to protect the motor in the event of a stall condition occurring. In the event of a stall condition the STALL icon will be displayed on the control panel and the instrument will stop. This condition may simply occur due to overloading the paddles in which case the sample size should be reduced (see 2.4 for Display Icons)

NOTE: -

A motor electrical current limiting device instrument is incorporated into the control circuit. Upon initial start-up a short time may elapse before the motor builds up torque and runs normally. This condition is more likely to prevail under the following circumstances: -

- i) Upon initial start-up following a period of transportation or storage.
- ii) The instrument has been stored or located in a cold environment (less than 10°C allowing the rubber connectors to become stiff).

For condition (i) run the instrument for 5 - 10 minutes, preferably with a number of stop-start cycles. For condition (ii) allow the instrument to stand in a warm environment as detailed in Section 3.1, followed by a short period of running with stop-start cycles.

3. MAINTENANCE

3.1 Replacing Primary Fuses

The primary fuses can only be removed with the aid of a tool, typically a screwdriver, since they are not considered operative replaceable. In the event of a fuse failure we recommend the equipment and mains electrical supply is checked by a competent qualified electrician.

WARNING: - When replacing fuses ensure they are replaced with fuses of the same rating and specification, refer to the appropriate model specification section of this manual. Please contact **Seward Technical Service** if in doubt.

3.2 Servicing and Spare Parts

Suitably qualified persons should only carry out internal servicing and maintenance. A Maintenance Manual is available giving full details of servicing and repair procedures, wiring diagrams, parts identification and general assembly drawings. We recommend as a matter of routine that the instrument is inspected and serviced at least every six months or sooner if extensively used.

CAUTION: - This equipment should **not** be used if damaged in any way. If in doubt please contact your local **Seward Ltd** authorised service centre.

3.3. Cleaning

The Stomacher® machines are very simple to clean. The external surface can be cleaned using a laboratory disinfectant and clean cloth. The processing chamber is easily cleaned by lifting the door from its lower hinge to gain access to the chamber.

4. SPECIFICATIONS

Model	American and Japanese Product	EU Product
Cat No.	4500/000/AJ	4500/000/EU
Dimensions	480mm wide x 480mm deep x 445mm high (unpacked)	480mm wide x 480mm deep x 445mm high (unpacked)
Weight	36kg (unpacked)	36kg (unpacked)
Supply Voltage	100 - 120V	220 - 250V
Supply Frequency	50-60Hz	50-60Hz
Plug Top Fuse		F5A (UK cord set only)
Mains Inlet Fuses*	T2.0A 250V 5x20mm, breaking capacity: 100A @ 250V	T1.0A 250V 5x20mm, breaking capacity: 35A @ 250V
Transformer Fuse*	T250mA 250V 5x20mm, breaking capacity: 35A @ 250V	T250mA 250V 5x20mm, breaking capacity: 35A @ 250V
PCB Fuse*	F2.5A 250V 5x20mm, breaking capacity: 100A @ 250V	F2.5A 250V 5x20mm, breaking capacity: 100A @ 250V
Insulation	Class 1 (Earthed)	Class 1 (Earthed)
Intallation	Over Voltage Category II	Over Voltage Category II
Pollution	Pollution Degree 2	Pollution Degree 2
Duty Cycle	Continuous	Continuous
Rated Load	120W	120W
Disposable Bag Size	380mm x 508mm	380mm x 508mm
Minimum Recommended Capacity	1000ml	1000ml
Maximum Recommended Capacity	3500ml	3500ml
Maximum Recommended Sample Temperature	60°C	60°C
Recommended Operating Ambient Temperature Range	10-35°C	10-35°C
Recommended Operating Relative Humidity Range	10-89%	10-89%
Adjustable Timer Settings	0 seconds – 99 minutes, 59 seconds (±5%)	0 seconds – 99 minutes, 59 seconds (±5%)
No Load Paddle Speeds (@ nominal 20°C)	125rpm (±5%) LOW 150rpm (±5%) NORM. 175rpm (±5%) HIGH	125rpm (±5%) LOW 150rpm (±5%) NORM. 175rpm (±5%) HIGH
Paddle Clearance	0-20mm	0-20mm

5. Warranty Statement

Each of the Stomacher® machines requires very little in the way of maintenance due to the quality of its components and manufacture. Such is the quality of the Stomacher® machines that they are supported by a full 3 year warranty.

All Seward Stomachers® are protected by a 36 month warranty covering faulty workmanship and materials. In the event of a fault developing within this period, please contact Seward Customer Service who will organise the collection/return of the instrument for warranty repair and/or replacement at Seward's discretion.

The warranty is void if the instrument has been damaged as a result of unauthorised service, modification or subject to neglect, misuse, accident, improper installation or operation.

6. Compliance

Seward Stomachers® are designed and manufactured to conform to the following standards: -

- IEC 61010-1 : 1990 Safety Requirements for Electrical Equipment for Measurement, Control and Laboratory Use.
- This equipment complies with the essential requirements of the European Council Directive 2006/42/CE relating to EMC and carries the CE mark.
- IEC 61010-1:2010, IEC 61010-2-51:2015 Safety Requirement for Electrical Equipment for Measurement, Control and Laboratory Use
- EMC Directive 2014/30/EU
- Low Voltage Directive 2014/35/EU
- Machinery Directive 2006/42/CE
- IEC61010-1 1990 Safety Requirement for Electrical Equipment for Measurement, Control and Laboratory Use UL 3101-1 1993 Electrical Equipment for Laboratory Use General Requirements
- A full list of compliance is detailed on our declaration of conformity and available on our website or from our customer services team.

7. Storage and Transport

Recommended storage and transport conditions are:-

Ambient Temperature Range -20 to + 50°C

Relative Humidity Range 10 - 90%

Seward Stomachers® should ideally be stored in a clean environment and for long periods of storage it should be re-packed in the original packaging.

Seward Stomachers® should be transported in the original packaging.

seward
World leaders in sample preparation



Please contact us for further information:

Seward Limited
Technology Centre
Easting Close
Worthing
West Sussex, BN14 8HQ
United Kingdom

Phone +44 (0)1903 524 600
Email info@seward.co.uk

Seward Laboratory Systems Inc. (USA)
155 Keyland Court
Bohemia
NY 11716
USA

Phone +1 631 337 1808
Email info@sewardusa.com

FermionX GmbH
Münstertäler Straße 12
Eschbach
DE-79427
Germany

Email info@seward.co.uk

www.seward.co.uk



Seward is a part of the FermionX Group.